

# Construction of a Heterodyne Receiver for Band 1 of ALMA

N. Reyes<sup>1</sup>, P. Zorzi<sup>1</sup>, C. Jarufe<sup>1</sup>, P. Altamirano<sup>2</sup>, F. P. Mena<sup>1\*</sup>, J. Pizarro<sup>2</sup>, L. Bronfman<sup>2</sup>, J. May<sup>2</sup>, C. Granet<sup>3</sup>, and E. Michael<sup>1</sup>

<sup>1</sup>Electrical Engineering Department, Universidad de Chile, Av. Tupper 2007, Santiago, Chile

<sup>2</sup>Astronomy Department, Universidad de Chile, Camino El Observatorio 1515, Santiago, Chile

<sup>3</sup>BAE Systems Australia Ltd, 40-52 Talavera Road, North Ryde 2113, Australia

\*Contact: pmena@ing.uchile.cl, phone +56-2-978 4888

**Abstract**— In this paper we present the construction and test results of several parts (horn, orthomode transducer, RF amplifier, and waveguide filter) towards the fabrication of a prototype heterodyne receiver for Band 1 of ALMA (31–45 GHz).

## I. INTRODUCTION

The Atacama Large Millimeter Array (ALMA) is the largest millimeter array ever constructed. Every one of its constituent antennas will cover the spectroscopic window allowed by the atmospheric transmission at the construction site with ten different bands. Despite being declared as a high scientific priority, Band 1 (31–45 GHz) was not selected for construction during the initial phase of the project. Universidad de Chile has started a program for the construction of a prototype receiver for Band 1 of ALMA. The overall design has been presented elsewhere [1]. Here we present the construction and testing results of several of its parts.

## II. LAYOUT OF THE RECEIVER

For the sake of completeness we reproduce in Fig. 1 the basic layout of the receiver we plan to construct [1]. The incoming RF signal is coupled with the horn via a lens (Sec. III-A). The signal is then divided in its polarization components in an orthomode transducer (Sec. III-B). Each polarization signal is amplified in two consecutive high electron-mobility transistors (HEMT) cooled at 20 K (Sec. III-C). Finally, the amplified signals are filtered to suppress the lower sideband (Sec. III-D) and mixed in separate Schottky diodes.

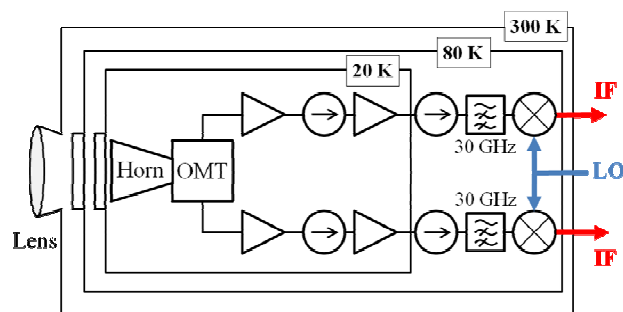

Fig. 1. Layout of the RF components of the receiver proposed for Band 1 of ALMA. All these components will be inside the cryostat and mounted in the so-called cold-cartridge assembly.

## III. CONSTRUCTION AND RESULTS

### A. Corrugated Horn

The details of the optical system design (lens-horn) are presented in an accompanying paper [2]. We have constructed an optimized spline-profile corrugated horn in the split-block technique (Fig. 2). Simulations indicate that it has similar performance to a normal corrugated horn but has the advantage of being almost half its size. For its characterization we are building a beam-pattern measurement set up.

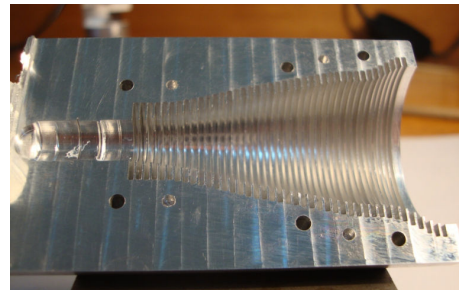

Fig. 2. One half of the optimized spline-profile corrugated horn constructed as a split-block.

### B. Orthomode Transducer

We have scaled the orthomode transducer (OMT) introduced by Asayama for Band 4 of ALMA [4]. It has been constructed as a split-block made out of three parts (Fig. 3). Its performance is excellent as demonstrated in Fig. 4.

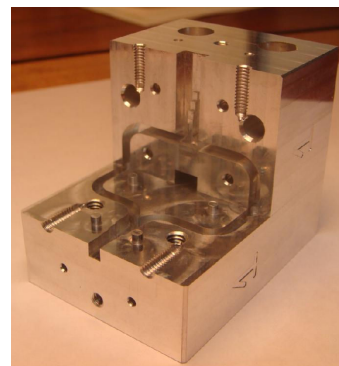

Fig. 3. Orthomode transducer constructed in the split-block technique.

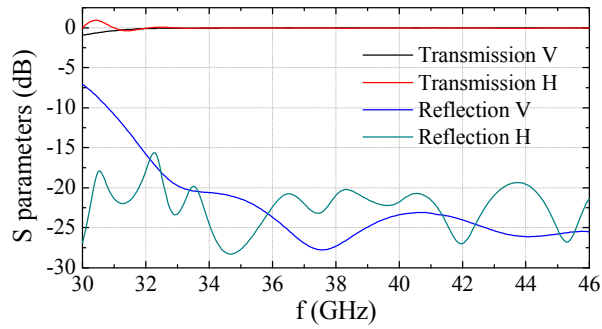

Fig. 4 Measured S-parameters of the orthomode transducer.

### C. RF amplifier

For amplification we will use chips based on high electron mobility transistors. In a first attempt to test our packaging capabilities, we have integrated commercial amplifiers [3] into a split block (Fig. 5). As demonstrated in Fig. 6 the results are excellent and in accordance with the original specifications of the commercial chips.

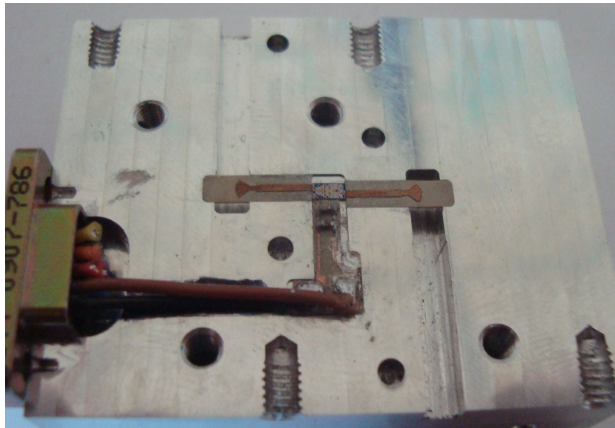

Fig. 5 Commercial chip packed in a split block.

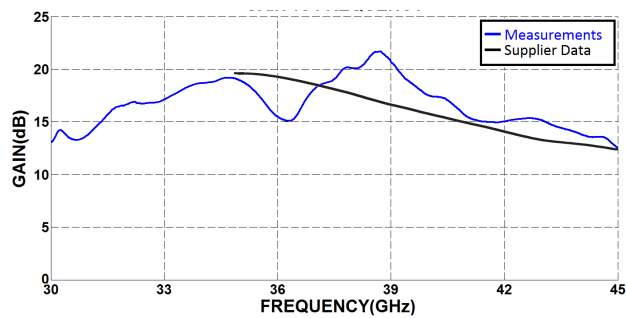

Fig. 6 Gain of the packaged amplifier.

### D. Filter for Lower-Sideband Suppression

An important part in the system we are proposing is a filter that suppresses the lower sideband. We designed and constructed a waveguide-base filter as shown in Fig. 7. The results presented in Fig. 8 are in excellent agreement with the simulations.

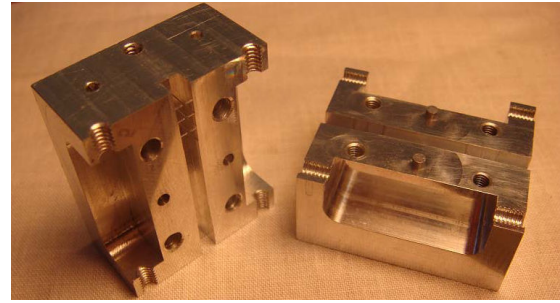

Fig. 7 Filter for lower band suppression.

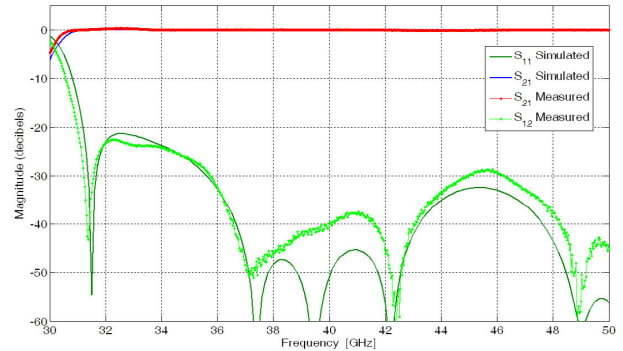

Fig. 8 Simulated and measured S-parameters of the filter.

## IV. CONCLUSIONS AND FUTURE WORK

We are currently working on fabricating and testing several parts of a heterodyne receiver for Band 1 of ALMA. So far, they show excellent response in accordance with the simulations. Our next step is to start with the integration of the receiver.

### ACKNOWLEDGMENT

This work received support from the Center of Excellence in Astrophysics and Associated Technologies (PBF 06), and from the ALMA-CONICYT Fund for the Development of Chilean Astronomy (Projects 31080003 and 31080004).

### REFERENCES

- [1] N. Reyes, P. Zorzi, F. P. Mena, C. Granet, E. Michael, L. Bronfman, and J. May, "Design of a Heterodyne Receiver for Band 1 of ALMA," in *Proc. ISSTT'09*, 2009, paper P8D, p. 311.
- [2] P. Zorzi, D. Henke, S. Claude, F.P. Mena, L. Bronfman, and J. May, "Revisiting the ALMA Band 1 optics design," presented in *ISSTT'10*, 2010, paper P5-6.
- [3] *GaAs HEMT MMIC low noise amplifier (HMC-ALH376)*, Hitite, 2008.
- [4] S. Asayama, "Double-ridged Orthomode Transducer for ALMA Band 4 receiver," NAOJ internal MEMO, 2007.